

TAYOR[®]

CNC Cutting Machine Department

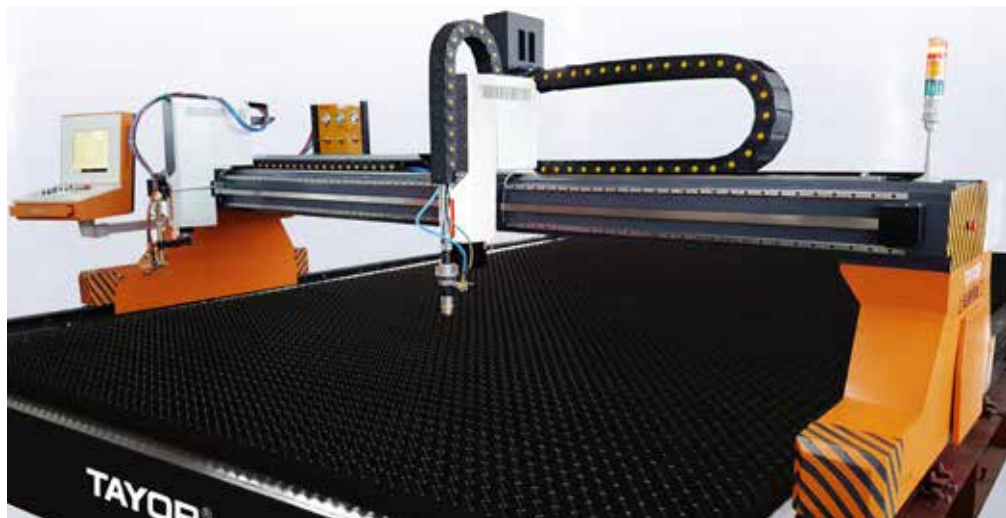

CNC Cutting Machine

Heavy Duty & Precision



Shanghai TAYOR Heavy Industry (Group) Co., Ltd.
Advanced manufacturer of cnc cutting and welding machine in Shanghai, China.

3 manufacturing bases, 10 manufacturing enterprises
 1 welding technology research institute, 1 welding training school
 100,000m² cutting and welding machine manufacturing base
 Over 1,000 staff, 100 senior technicians
 Over 500 sets heavy duty cnc plasma and flame cutting machine sales volume every year
 Over 300 types cutting and welding equipments
 Exported to more than 100 countries and regions
 30 minutes driving away from Shanghai PVG airport.
 CE & ISO9001:2008 certified

Application Industry: Ship Building, Construction Equipment, Elevator Manufacturing, Steel Mechanical Processing, Petroleum Pipeline, Steel Construction, Agriculture Machine, Transport Equipment, Aerospace Industry, Bridge Building, Pressure Vessel, Electric Power Industry, etc.



CONTENTS

1. CNC Steel Plate Cutting Machine		4
Plasma and Flame	1.1 Economic Table Type Series CNCTG	4
	1.2 Precision Table Type Series CNC TGM	6
	1.3 Gantry Type Series CNC CSG	8
	1.4 Strip Cutting Machine Series ZT	13
Laser	1.5 CNC Laser Cutting Machine TF PRO	14
	1.6 CNC Laser Cutting Machine TF EDGE+	15
	1.7 CNC Laser Cutting Machine TF EDGE	16
	1.8 CNC Laser Plate & Tube Cutting Machine TP	17
	1.9 Gantry Type CNC Laser Cutting Machine TF G	18
	1.10 CNC Laser Tube Cutting Machine TP PRO	19
	1.11 3D Laser Cutting Machine TF 3D	20
	1.12 CNC Water Jet Cutting Machine	21
2. CNC Steel Pipe Cutting Machine		22
2.1 CNC Pipe Profile Cutting Machine Series CNCXG		22
2.2 Structural Steel Cutting Machine Series CNCFG		24
2.3 Flat Steel Cutting Machine With Auto-Loading &Unloading System		25
3. Customized Options-CNC Controller		26
4. Customized Options-Nesting Software		27
5. Customized Options-Plasma Source		28
6. Customized Options-Plasma Dust Collection		30
7. Customized Options- Other Accessories		31





Economical and Practical

With combination of digital control, high precision mechanical driving and thermal cutting technique, it will be able to keep stable cutting quality with highest standard under the long-term and high-intensive working conditions.

Machine Details



Machine Features

- Stable and reliable modularization cutting unit
- Quick installation, no need foundation preparation, space saving
- High accuracy mechanical driving
- Good finish surface, almost no secondary treatment
- Low use-cost, without special maintenance
- Friendly operation panel, easy-to-use
- Automatic programming, optimization nesting and piercing path, save steel efficiently
- G code and M code readable
- DXF/DWG files programming and nestling
- USB key data transmission

Technical Specification

Cutting Technical Data				
Model	CNCTG1520	CNCTG1530	CNCTG2060	CNCTG2580
Effective Cutting Area (mm)	1500x2000	1500x3000	2000x6000	2500x8000
Cutting Thickness(mm)	Flame:5-60mm Plasma:1-50mm			
Basic Components				
Cutting Mode	Plasma and Oxy-Fuel/Flame			
Table Structure	Joint Section			
Drive Mode	AC Servo motor, Dual-drive or Single-drive			
Cutting Torch Number	Customization			
Driving Motor	Panasonic/Yaskawa			
CNC Controller	Hypertherm EDGE CONNECT TC/EDGE CONNECT, LKNC-3200			
Available Plasma Power source	Hypertherm, Kjellberg, Victor, ESAB			
Software	Fastcam, SmartNest, Hypertherm			
Dust Extraction	Air duct, water table			
Other Data				
Operation Language	Multi-language			
Input Power Voltage	3×380V±10% 50Hz/according to user's local condition			
Optional Items	Platen device, zinc powder marking device, punching device, laser point, air conditioner, etc.			

*Above machines can be customized.





High Speed and Precision

CNCTMG Series of Precision Table type Cutting Machine is integral type cutting equipment with high speed and precision. With precision linear guides and world well-known high definition plasma source such as Hypertherm, Kjellberg, Thermal Dynamics, it shows high guiding accuracy, excellent running stability and high precision cutting ability. It is able to keep highest standard cutting process under long-term and high-intensive working conditions.

Machine Details

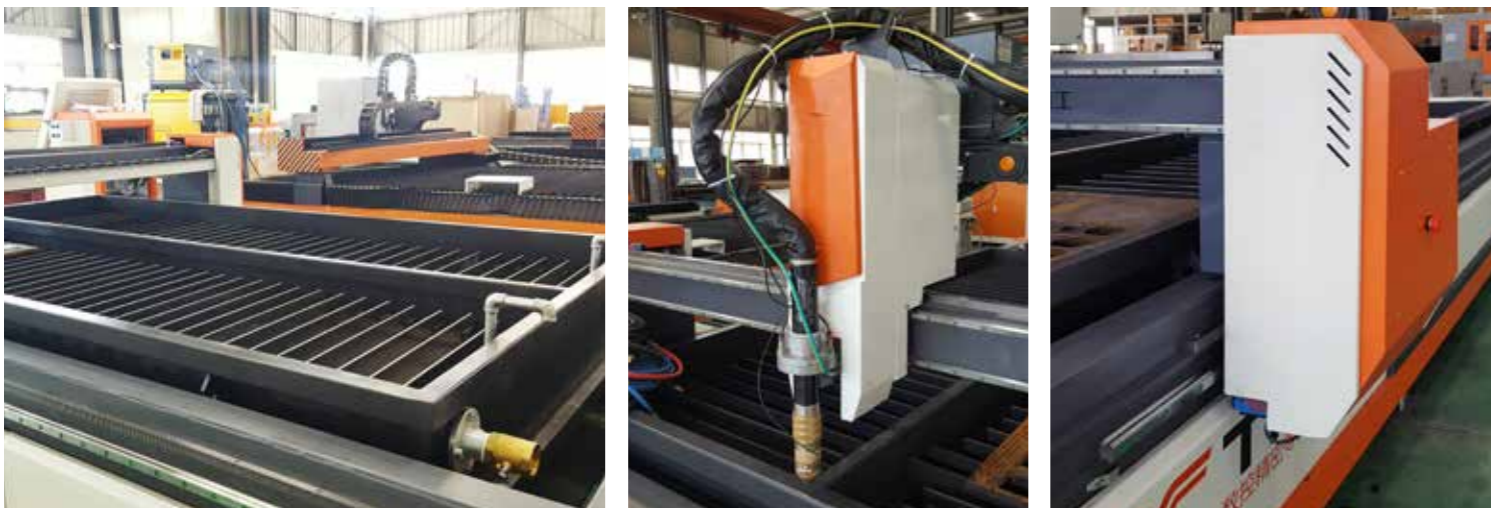

Machine Features

- Compact and integral type modularization cutting unit, excellent rigidity.
- Without foundation preparation, space saving, heavy duty and durable
- Precision linear guide driving, low deformation during high speed cutting
- Great finish surface, no slag, dispense with secondary treatment
- Low use-cost, without special maintenance, friendly operator panel, easy to learn
- Utility CNC system, reliable and safe
- G code and M code readable
- DXF/DWG file programming and nestling
- USB key data transmission

Technical Specification

Cutting Technical Data		
Model	CNCTMG1530	CNCTMG1560
Effective Cutting Area (mm)	1500x3000	1500x6000
Machine Size(mm)	2000x4000	2000x7000
Cutting Thickness(mm)	Flame:5-60mm Plasma:1-50mm	
Basic components		
Cutting Mode	High Definition Plasma and Oxy-Fuel/Flame	
Table Structure	Integral type	
Drive Mode	AC Servo motor, Dual-drive	
Cutting Torch Number	Customization	
Driving Motor	Panasonic/ Yaskawa	
CNC Controller	Hypertherm EDGE CONNECT TC/EDGE CONNECT, LKNC-3200	
Available Plasma Power source	Hypertherm, Kjellberg, Victor, ESAB	
Software	Fastcam, SmartNest, Hypertherm	
Dust Extraction	Air duct, water table	
Other Data		
Operation Language	Multilanguage	
Inclination Angle	2-4degree	
Input Power Voltage	3×380V±10% 50Hz/according to user's local condition	
Optional Items	Platen device, zinc powder marking device, punching device, laser point, air conditioner, etc.	

*Above machines can be customized.



Gantry Type Series CNCSG

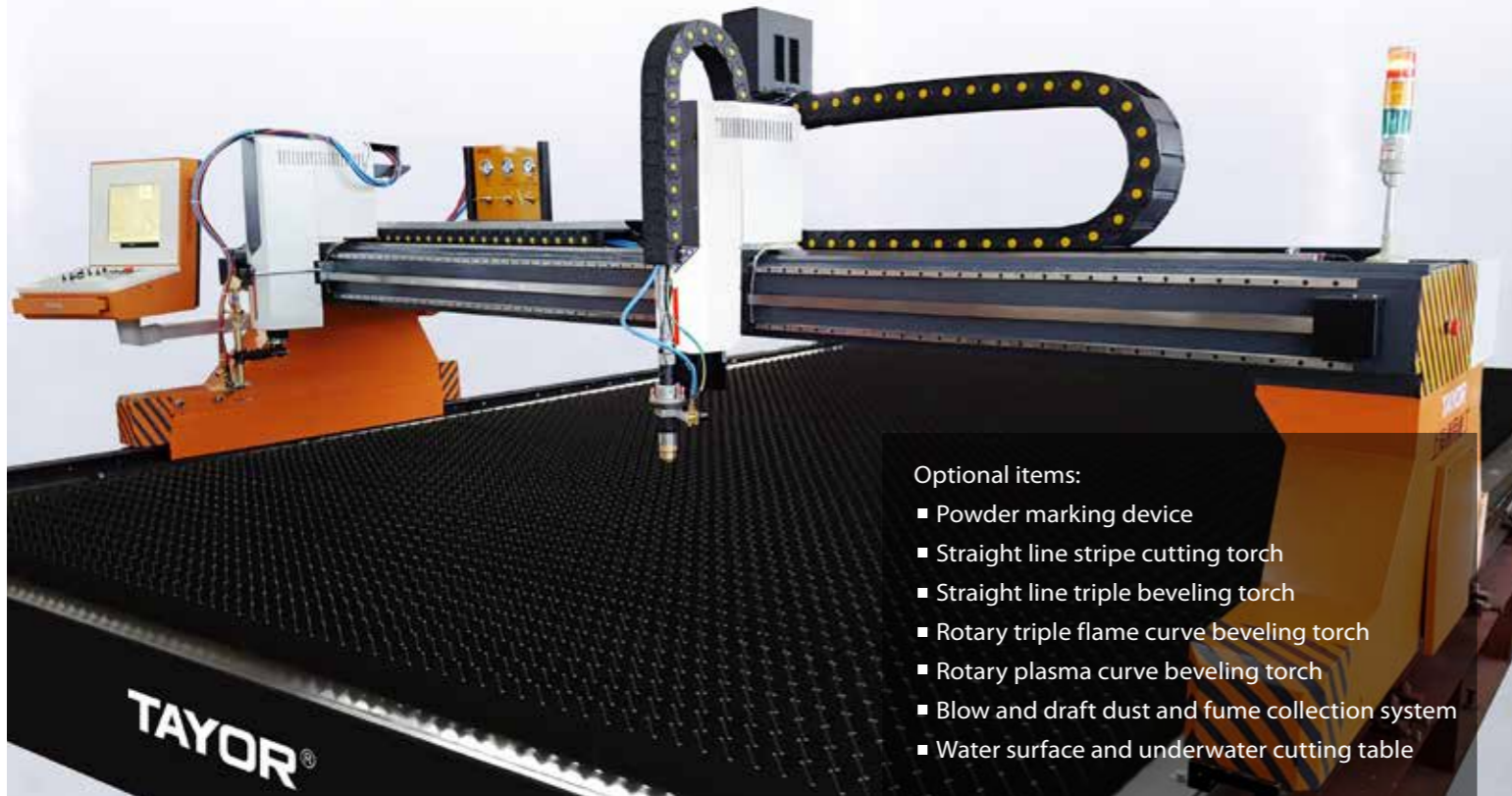

Optional items:

- Powder marking device
- Straight line stripe cutting torch
- Straight line triple beveling torch
- Rotary triple flame curve beveling torch
- Rotary plasma curve beveling torch
- Blow and draft dust and fume collection system
- Water surface and underwater cutting table

Heavy Duty and Precision

Gantry Type Series CNCSG is heavy duty, precision machine, specially designed for cutting large steel plate, can be equipped with multiple plasma torches and flame torches. It is very efficient, with excellent cutting quality.

Machine Details



Gantry Type CNC Plasma And Flame Cutting Machine

Machine Features

- Gantry and box type welded structure, annealed, long service life, steady and durable under heavy load and high duty cycle condition.
- Gapless gearing transmit, stable and smooth running in high speed, so that we can achieve excellent cutting quality.
- Integrated auto-ignition with automatic height controller, keep the proper height between cutting torch and work piece, so that we can achieve the best cutting quality.
- Able to cut work piece with several torches at the same time, can improve cutting efficiency
- Low use and maintenance cost, dispensing special maintenance, friendly operator interface, easy to learn
- Reliable, safe cnc system, automatic programming, optimization nesting and piercing path, so that we can save steel effectively

Technical Specification

Cutting Technical Data							
Model	CNCSG3000	CNCSG3500	CNCSG4000	CNCSG5000	CNCSG6000	CNCSG7000	CNCSG8000
Effective Cutting Width (mm)	2200	2700	3200	4200	5200	6200	7200
Track Width (mm)	3000	3500	4000	5000	6000	7000	8000
Effective Cutting Length (m)	2m less than track length						
Cutting Thickness(mm)	Flame:5-120mm(Max 300mm) Plasma:1-80mm						
Basic Components							
Cutting Mode	Plasma and Oxy-Fuel/Flame						
Drive Mode	AC Servo motor, Dual-drive						
Cutting Torch Number	Customization						
Driving Motor	Panasonic/Yaskawa						
CNC Controller	Hypertherm EDGE CONNECT TC/EDGE CONNECT, LKNC-3200						
Available Plasma Power	Hypertherm, Kjellberg, Victor, ESAB						
Programming Software	Fastcam, SmartNest, Hypertherm						
Input Power Voltage	3×380V±10% 50HZ/according to user's local condition						
Operation Language	Multilanguage						

*Above machines can be customized.



Option: CNC Plasma Bevel Cutting Machine



Advantages

1. Adopting advanced cnc controller Hypertherm EDGE Pro, and Fastcam Bevel version nesting software, can cut all kinds of V, Y bevel, both in straight lines and curve lines.
2. Adopting high accuracy automatic THC, height control accuracy can be up to $\pm 0.1\text{mm}$.
3. Having 5 axis, can achieve all kinds of bevel cutting.
4. Plasma head can rotate 360° with no limit, equipped with heavy duty, high accuracy gantry, can achieve excellent bevel cutting quality.

Cutting Samples



Option: CNC Flame Curve Bevel Cutting Machine



Advantages

1. Unlimited rotatory flame curve cutting machine, bevel angle and cutting path can be adjusted when programming.
2. Having our own TAYOR patent in sensing plate height, the bevel torch can sense the plate automatically when cutting, so that we can guarantee excellent bevel cutting quality.

Cutting Samples





Advantages

- 1. Combined with cold process drilling and thermal plasma and flame cutting, with only once programming, the machine can achieve drilling and cutting automatically. Equipped with high speed drilling and high efficiency plasma cutting, can highly improve production efficiency.
- 2. Drilling with high accuracy, drilling thickness can be up to 25mm, drilling diameter 5-30mm.
- 3. Plasma and flame cutting are both available. Zinc powder marking device is also recommended to show cutting path.

Using Site



Advantages

Specially designed for flame strip cutting, can equip plenty of torches to improve production efficiency, very economic and efficient.

Using Site



CNC Laser Cutting Machine TF PRO



Technical

Working Area	3015/4020/6020
Max Position Speed	169m/min
X, Y axis Position Accuracy	0.05 mm
X,Y axis Repeatability Accuracy	0.025 mm
Laser Power	2KW/ 3KW/ 4KW/ 5KW/ 6KW/ 8KW
Max Cutting Thickness(3KW)	Mild Steel 25mm; Stainless Steel 12mm

Laser Cutting Functions

- | | |
|---------------------|---------------------|
| 1 Height Follow-Up | 6 Lead Line |
| 2 Power Control | 7 Auto Edge-Finding |
| 3 Reverse Function | 8 Leapfrog Function |
| 4 Breakpoint Return | 9 Common Line |
| 5 Multi Piercing | 10 Marking Function |

Using Site



CNC Laser Cutting Machine TF EDGE+



Technical

Working Area	3015/4020/6020
Max Position Speed	80m/min
X, Y axis Position Accuracy	0.05 mm
X,Y axis Repeatability Accuracy	0.025 mm
Laser Power	500W/700W/750W/1000W/2000W
Max Cutting Thickness(2000W)	Mild Steel 20mm; Stainless Steel 10mm

Laser Cutting Functions

- | | |
|---------------------|---------------------|
| 1 Height Follow-Up | 6 Lead Line |
| 2 Power Control | 7 Auto Edge-Finding |
| 3 Reverse Function | 8 Leapfrog Function |
| 4 Breakpoint Return | 9 Common Line |
| 5 Multi Piercing | 10 Marking Function |

Using Site

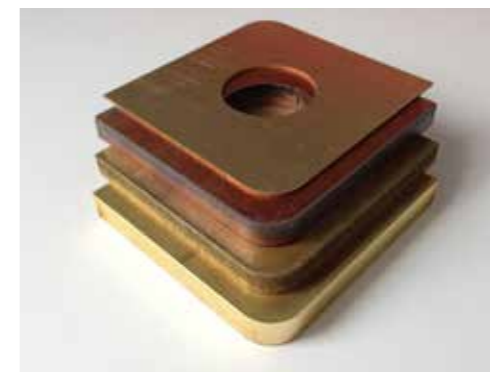

CNC Laser Cutting Machine TF EDGE



Technical

Working Area	3015/4020/6020
Max Position Speed	80m/min
X, Y axis Position Accuracy	0.05 mm
X,Y axis Repeatability Accuracy	0.025 mm
Laser Power	500W/700W/750W/1000W/1200W
Max Cutting Thickness(500W)	Mild Steel 6mm; Stainless Steel 3mm

Laser Cutting Functions

- | | |
|---------------------|---------------------|
| 1 Height Follow-Up | 6 Lead Line |
| 2 Power Control | 7 Auto Edge-Finding |
| 3 Reverse Function | 8 Leapfrog Function |
| 4 Breakpoint Return | 9 Common Line |
| 5 Multi Piercing | 10 Marking Function |

Using Site

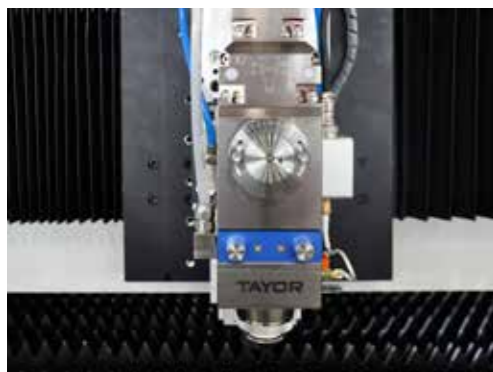

CNC Laser Plate & Tube Cutting Machine TP



Technical

Plate Cutting Area	3015/6015
Tube Cutting Diameter	30mm-220mm
Tube Cutting Length	Less than 6M
Max Position Speed	80m/min
X Y axis Position Accuracy	0.05 mm
X Y axis Repeatability Accuracy	0.025 mm
Laser Power	500W/700W/750W/1000W/1200W
Max Cutting Thickness(500W)	Mild Steel 6mm; Stainless Steel 3mm

Laser Cutting Functions

- | | |
|---------------------|---------------------|
| 1 Height Follow-Up | 6 Lead Line |
| 2 Power Control | 7 Auto Edge-Finding |
| 3 Reverse Function | 8 Leapfrog Function |
| 4 Breakpoint Return | 9 Common Line |
| 5 Multi Piercing | 10 Marking Function |

Using Site

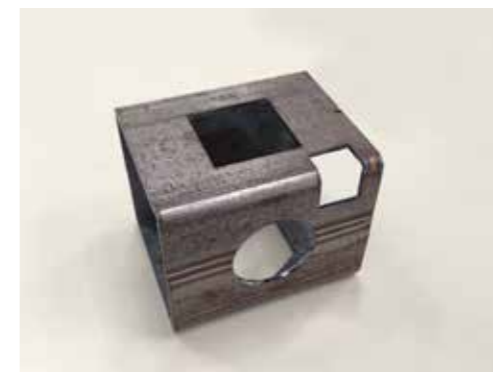

Gantry Type CNC Laser Cutting Machine TF G



Technical

Working Area	18X3.5m Or Customized
Position Speed	25-50m/min
X Y axis Position Accuracy	0.05 mm
X Y axis Repeatability Accuracy	0.025 mm
Laser Power	2000W/3000W/4000W/6000W
Max Cutting Thickness(3000W)	Mild Steel 25mm; Stainless Steel 12mm

Laser Cutting Functions

- | | |
|---------------------|---------------------|
| 1 Height Follow-Up | 6 Lead Line |
| 2 Power Control | 7 Auto Edge-Finding |
| 3 Reverse Function | 8 Leapfrog Function |
| 4 Breakpoint Return | 9 Common Line |
| 5 Multi Piercing | 10 Marking Function |

Using Site



CNC Laser Tube Cutting Machine TP PRO



Technical

Tube Cutting Diameter	20mm-300mm
Tube Cutting Length	3M/6M
Max Position Speed	25 m/min
Tolerance	Cutting Length Tolerance: ± 0.1 mm. Hole Diameter Tolerance: ± 0.05 mm.
Laser Source	500W/1000W/2000W/3000W/4000W
Max Cutting Thickness(1KW)	Mild Steel 12mm; Stainless Steel 6mm

Laser Cutting Functions

- | | |
|---------------------|---------------------|
| 1 Height Follow-Up | 6 Lead Line |
| 2 Power Control | 7 Auto Edge-Finding |
| 3 Reverse Function | 8 Leapfrog Function |
| 4 Breakpoint Return | 9 Common Line |
| 5 Multi Piercing | 10 Marking Function |

Using Site



TF 3D Series

3D Laser Cutting Machine TF 3D



Robot All Axis Rotation Angle

First Axis: +180°- 180°	Second Axis: +110°- 100°
Third Axis: +65°- 60°	Fourth Axis: +200°- 200°
Fifth Axis: +120°- 120°	Sixth Axis: +400°- 400°

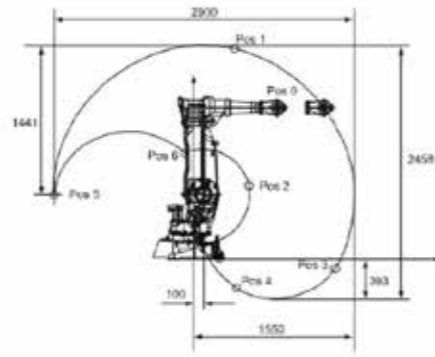

Using Site



CNC Water Jet Cutting Machine

CNCNG Series



High Accuracy and No Material Limit

There are virtually no limits to what water jet can cut, which is why companies of all kinds and sizes are realizing greater efficiency and productivity by implementing water jet in their operations. CNC Water Jet Cutting Machine CNCNG can cut any material plate, with thickness 0.5-150mm, including steel, stone, rubber, glass, etc.

Using Site



CNC Pipe Profile Cutting Machine



Optional items:

- 5 jaws concentric chuck
- Turning roll(cutting pipe dia can be up to 2500mm)
- Fastpipe/fastframe software
- Electric jaw
- Electric adjusting bracket
- Photoelectric sensor

Use of Equipment Performance

CNCXG series cnc pipe cutting machine is specially designed equipment for steel pipe 3-D automatic cutting.After input of basic data or leading proper format files, it is capable of automatically processing hole, beveling, grooving, multi-branch and shrimp sections.It is widely used in steel structure, ship building, bridge and steel tower building, petrochemical piping and pressure vessel industry.

Using Site



Machine Features

- Oxy-fuel and plasma cutting and beveling
- Maximum cutting pipe diameter 1600mm
- 3D Cutting
- Touch screen panel, convenient and fast data inputting, easy to use and learn
- Saving cutting data any time, able to create technical data base by user
- Compatible with Steel Structure designing software, expanding of machine function

Technical Specification

Technical Data						
Model	CNCXG300	CNCXG600	CNCXG800	CNCXG1250	CNCXG1400	CNCXG1600
Cutting Pipe Diameter (mm)	Φ40-300	Φ60-630	Φ60-800	Φ100-1250	Φ200-1400	Φ200-1600
Pipe Length(mm)	2000-12000	2000-12000	2000-12000	2000-12000	2000-12000	2000-12000
Cutting Speed (mm/min)	Flame: 50-750 Plasma: 50-5800					
Cutting Thickness(mm)	Flame:5-60mm Plasma:1-50mm					
Plasma Max Beveling Angle	±45°					
Flame Max Beveling Angle	±60°					
Basic Components						
Pipe Chuck	3 jaws concentric chuck					
Cutting Mode	Flame and Plasma					
Number Of Control Axis	2-6					
Driving Motor	Panasonic/Yaskawa					
Available Plasma Power	Hypertherm, Kjellberg, Victor, ESAB					
Other Data						
Operation Language	English or Chinese					
Input Power Voltage	3×380V±10% 50Hz / according to user's local condition					

*Above machines can be customized.

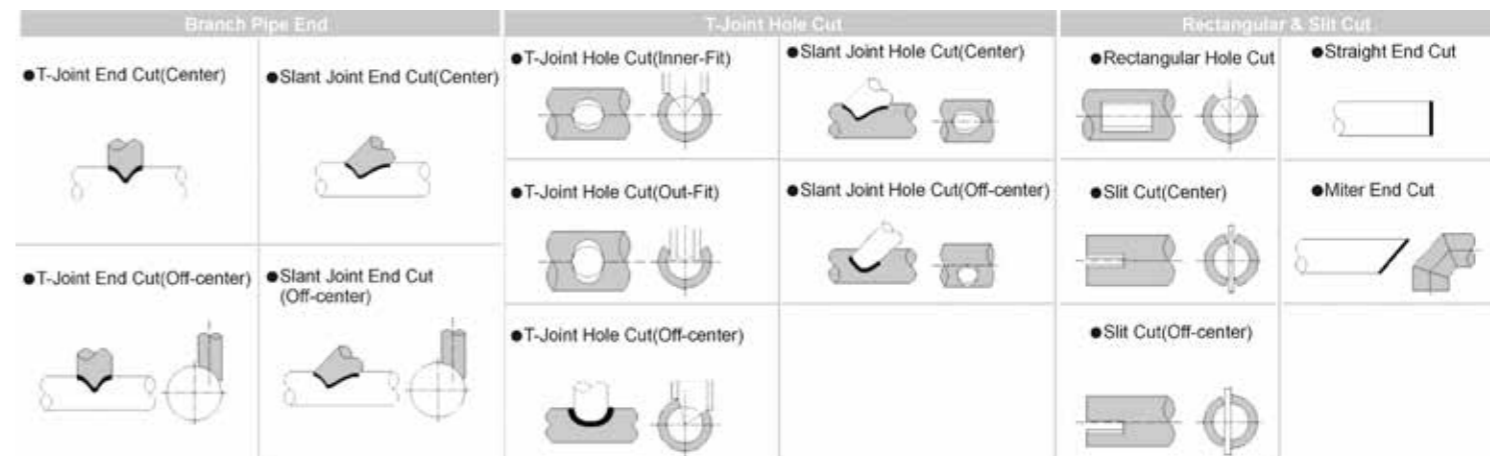



Use of Equipment Performance

The new developed CNCFG series CNC structural steel cutting machine is a high performance automation machine. With TAYOR's proprietary technology, the plasma torch makes 360 degree rotary motion around the structural steel. Which is able to realize structural steel fixed length cut-off cutting, various geometric shapes cutting as well as hole cutting. This machine is suitable for structural steel batch processing and high-efficiency cutting.

High Efficiency And Saving Labor Cost

Flat Steel Cutting Machine With Auto-loading & Unloading System is specially designed for customer, with TAYOR patent, which highly improve cutting efficiency and save much labor cost. Plasma head is fitted in enclosure, Auto-loading System will forward the material to plasma head for cutting, after finishing cutting, Auto-unloading System will deliver the working piece to specific pallet.

Technical Specification

Model	CNCFG
Cutting Mode	Plasma Cutting
Cutting Length	10 Meter or Customized
Work Piece Specification	On request
Max Moving Speed	12m/min
Axis Control	CNC multi-axis controlled

*Above machines can be customized.

Work piece type

- 1 | Unequal angle steel
- 2 | Channel beam
- 3 | Square tube
- 4 | Cold bend equal channel steel
- 5 | Flat-bulb Steel



Using Site





EDGE Connect

EDGE® Connect, Hypertherm's newest Computer Numeric Control (CNC) platform, delivers unmatched reliability, powerful embedded capabilities, and a high level of customizability. The smallest of the CNC configurations, the EDGE® Connect offers the greatest flexibility for machine integration. Cutting machine OEMs provide the touch screen and any operator switches.



EDGE Connect TC

EDGE CONNECT TC is the most advanced cnc controller from Hypertherm, it is integral solution and touch screen from Hypertherm. Based on our proprietary, industry-leading Phoenix® CNC platform, the system offers new, advanced software features – including ProNest® CNC automatic nesting delivering SureCut™ technology – along with enhanced hardware.



LKNC-3200

CNC Cutting Control System LKNC-3200 is a controller with 17" high resolution LCD touch screen. It can be connected with any of the PCs in the network by network interface to transfer cutting files, providing great convenience to operators and programmers. This product is suitable for any type of oxygen and plasma cutting machine.



SJTU-SK

The controller SJTU-SK is stable and economic product, which is integrated many merits of the same productions at home and aboard. SJTU-SK can control the motion of two axis, which is apt to the application of plasma and flame cutting. It provides menu or illustration for all the operations for the convenience of users.



Burny Dagger NC

The productivity of a high end control in an affordable, flexible package. Burny DaggerNC™ is the most compact, low-cost controller on the market. The DaggerNC™ offers easy relay based I/O, support for advanced plasma features and integrated torch height control (Burny SmartHC™).



Burny 10 LCD Plus

The Burny 10 LCD PLUS CNC Control produces extremely precise and repeatable motion control by utilizing Windows® XP Embedded (operating system) and tenAsys INtime® (real-time motion control). The PLUS also contains a large, 15", full-color, touch screen interface as well as familiar features common to all Burny PRODUCTS.



Advantech Controller (For CNCXG series pipe cutting)

The controller is 12.1" Fanless panel PC that delivers high performance while consuming low power. The controller operates with low noise and provides display resolutions up to 1024 x 768 (XGA) pixels. Advantech's customization services and optional accessories including wireless modules, battery packs, and SATA optical devices, allow system integrators to design tailor-made solutions to a host of industrial applications.

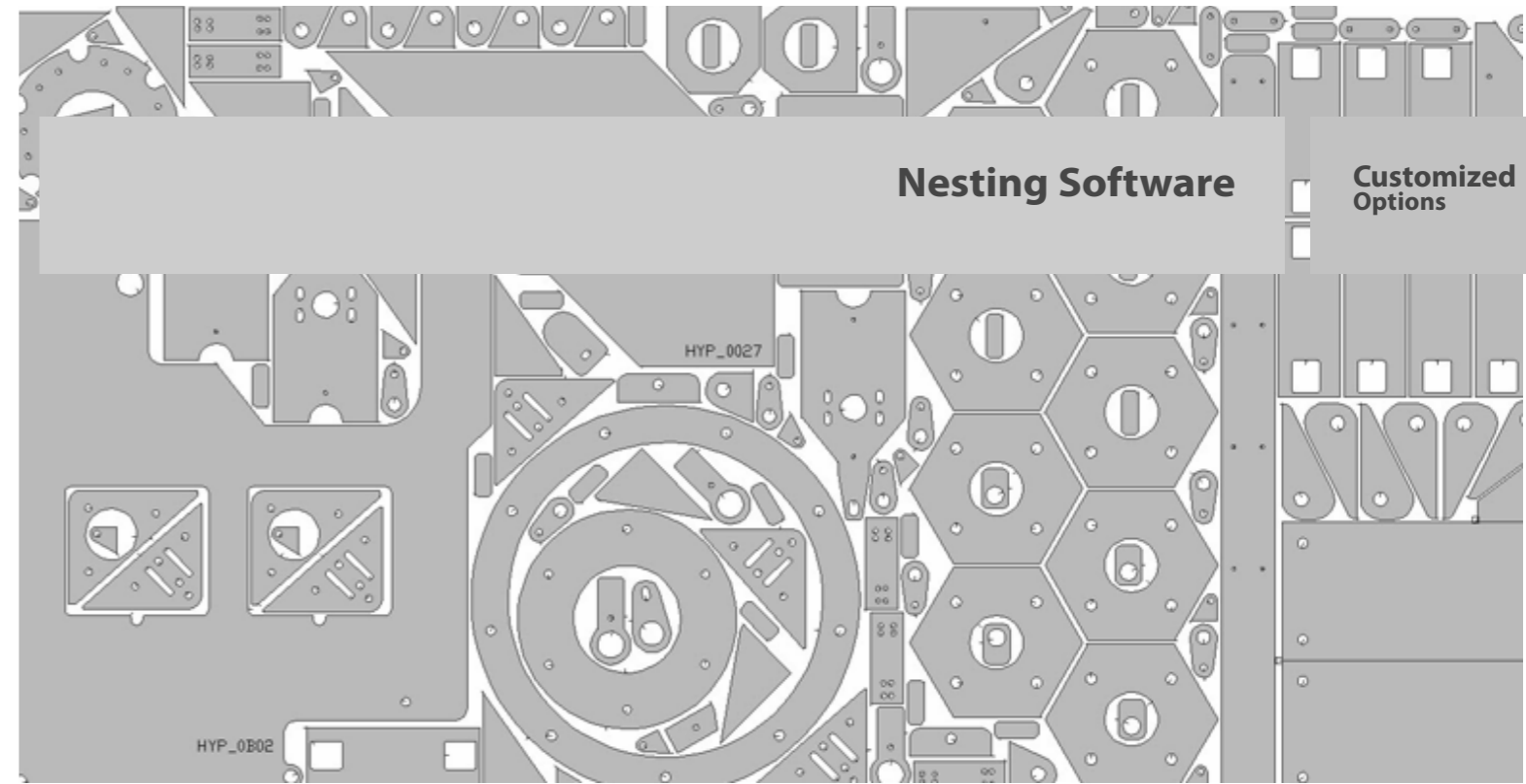

Plate Nesting Software

1. Fastcam

FastCAM have over 40 products, grouped as follows. All are designed to be used by tradespeople and can be used independent of any other software, unless specified. With the new affordable pricing/delivery structure, we no longer maintain demo download versions of all the individual programs however the features are showcased on FastCAM TV and we are happy to schedule interactive online demonstrations for our programming systems. OEM versions are available on selected products.

2. SmartNest

SmartNest is a CNC nesting programming software with independent intellectual property rights which researched by famous university research team after more than twenty years. It fully absorbs the strengths of a number of similar products at home and abroad in the development and improvement process, improves and perfects according to the actual situation of Chinese enterprises and operating habits of Chinese engineers. SmartNest nesting software divides into two versions as professional version and machine version, and is suitable for flame cutting machine, plasma cutting machine, laser cutting machine, water jet cutting machine and so on.

3. Hypertherm

Hypertherm is an industry leader in CAM nesting software for CNC sheet and plate cutting applications, including plasma, laser, waterjet, oxyfuel, combination punch, drill/tap/spindle, and turret punch. Our ProNest® Nesting Software, TurboNest® Nesting Software and NestMaster™ Nesting Software provide solutions to all of your profile cutting needs.

Pipe Nesting software

Fastframe

FastFRAME® is a powerful production tool that can save hundreds of hours in the design stage of complex space frame developments. Complete structural frames can be completed in days! Of equal value, the extraction of fabrication data needed for processing is simple so you can validate the structure before processing begins. FastFRAME® imports DXF/DWG drawings from steel detailing programs and provides all of the intersection details for single and multi-pipe intersections, including sequencing for construction.





Common Plasma Source-Hypertherm

	Model	PowerMAX65	PowerMAX85	PowerMAX105	PowerMAX125	MAXPRO200	HSD130
MS	Max Piercing Thickness	10mm	12mm	20mm	25mm	25mm(air) 30mm(O ₂)	20mm(air) 25mm(O ₂)
	Max Edge Start Cutting Thickness	12mm	16mm	40mm	40mm	50mm	32mm
SS	Max Piercing Thickness	10mm	12mm	20mm	20mm	25mm	12mm
	Max Edge Start Cutting Thickness	12mm	16mm	32mm	40mm	50mm	20mm
AL	Max Piercing Thickness	12mm	12mm	20mm	25mm	25mm	20mm
	Max Edge Start Cutting Thickness	16mm	16mm	32mm	40mm	38mm	25mm
Reference Speed(MS)		10mm MS plate 1900mm/min	12mm MS plate 2000mm/min	12mm MS plate 2060mm/min	12mm MS plate 2510mm/min	12mm MS plate 2794mm/min	12mm MS plate 2050mm/min
Inclination Angle		5°	5°	5°	5°	4°-5°	4°-5°
Cutting Gas		Air	Air	Air	Air	Air, O ₂ , N ₂	Air, O ₂ , N ₂ , H35, F5
Power		8.4KW	12KW	16KW	21.9KW	33KW	19.5KW

High Definition Plasma Source-Hypertherm

	Model	HPR130XD	HPR260XD	XPR300	HPR400XD	HPR800XD
MS	Max Piercing Thickness	25mm(O ₂)	32mm	45mm(Standard O ₂) 50mm(Argon-assist)	50mm	50mm
	Max Edge Start Cutting Thickness	38mm	64mm	80mm	80mm	80mm
SS	Max Piercing Thickness	16mm	32mm	38mm	40mm	75mm
	Max Edge Start Cutting Thickness	25mm	50mm	75mm	80mm	160mm
AL	Max Piercing Thickness	16mm	25mm	38mm	40mm	75mm
	Max Edge Start Cutting Thickness	25mm	50mm	50mm	80mm	160mm
Reference Speed(MS)		12mm MS plate 2200mm/min	12mm MS plate 3850mm/min	12mm MS plate 3940mm/min	12mm MS plate 4430mm/min	12mm MS plate 4430mm/min
Inclination Angle		2°-4°	2°-4°	2°-4°	2°-4°	2°-4°
Cutting Gas		Air, O ₂ , N ₂ , H35, F5	Air, O ₂ , N ₂ , H35, F5	Air, O ₂ , N ₂ , H35, F5, Ar	Air, O ₂ , N ₂ , H35, F5	Air, O ₂ , N ₂ , H35, F5
Power		19.5KW	45.5KW	63KW	80KW	160KW



Common Plasma Source - Victor (Thermal Dynamics)

Model	CUTMASTER A60	CUTMASTER A80	CUTMASTER A120	AUTOCUT100	AUTOCUT200	AUTOCUT300
Max Piercing Thickness	10mm	12mm	16mm	15MM	25mm	35mm
Max Edge Start Cutting Thickness	25mm	30mm	35mm	30MM	50mm	75mm
Cutting Gas	Air	Air	Air	Air, Water, O ₂ , N ₂	Air, Water, O ₂ , N ₂	Air, Water, O ₂ , N ₂
Power	9KW	12KW	15.4KW	16KW	32KW	48KW

High Definition Plasma Source - Victor (Thermal Dynamics)

Model	ULTRACUT100	ULTRACUT200	ULTRACUT300	ULTRACUT400
Max Piercing Thickness	15mm	25mm	35mm	50mm
Max Edge Start Cutting Thickness	35mm	50mm	75mm	90mm
Cutting Gas	Air, Water, O ₂ , N ₂	Air, Water, O ₂ , N ₂	Air, Water, O ₂ , N ₂	Air, Water, O ₂ , N ₂
Power	18KW	36KW	54KW	72KW

HiFocus Series-Kjellberg

Model	HiFocus80i	HiFocus130i	HiFocus161i	HiFocus280i	HiFocus360i	HiFocus440i	HiFocus600i
Max Piercing Thickness	15mm	25mm	30mm	40mm	50mm	50mm	80mm
Max Edge Start Cutting Thickness	25mm	40mm	50mm	70mm	80mm	100mm(MS) 120mm(SS)	100mm(MS) 120mm(SS)
Cutting Gas	Air, O ₂	Air, O ₂ , Ar, H ₂ , N ₂	Air, O ₂ , Ar, H ₂ , N ₂	Air, O ₂ , Ar, H ₂ , N ₂	Air, O ₂ , Ar, H ₂ , N ₂	Air, O ₂ , Ar, H ₂ , N ₂	Air, O ₂ , Ar, H ₂ , N ₂

Smart Focus Series-Kjellberg

Model	Smart Focus 130	Smart Focus 200	Smart Focus 300	Smart Focus 400
Max Piercing Thickness	25mm	30mm	40mm	50mm
Max Edge Start Cutting Thickness	40mm	60mm	80mm	100mm
Cutting Gas	Air, O ₂ , Ar, H ₂ , N ₂	Air, O ₂ , Ar, H ₂ , N ₂	Air, O ₂ , Ar, H ₂ , N ₂	Air, O ₂ , Ar, H ₂ , N ₂

High Definition Plasma Source-ESAB

Model	EPP202	EPP362	EPP450	EPP601
Max Piercing Thickness	32mm(MS) 25mm(SS, Al)	40mm(MS) 32mm(SS, Al)	50mm(MS) 45mm(SS, Al)	50mm(MS) 75mm(SS, Al)
Max Edge Start Cutting Thickness	50mm(MS) 32mm(SS, Al)	65mm(MS) 50mm(SS, Al)	80mm(MS) 60mm(SS, Al)	80mm(MS) 150mm(SS, Al)
Cutting Gas	Air, O ₂ , N ₂ , etc	Air, O ₂ , N ₂ , etc	Air, O ₂ , N ₂ , etc	Air, O ₂ , N ₂ , etc

There will be lots of dust and smoke when plasma cutting, especially cutting thick steel plate. In order to protect operator's health and environment, we supply different solutions for dust collection:



1. Water Surface Cutting Table

The plate is above water for about 10mm, when plasma cutting, the water will collect about 80% dust and smoke. It is very economic and efficient.



2. Under Water Cutting Table

Under water cutting is more efficient for plasma cutting dust and smoke collection, but the cost of building under water cutting table is higher, and the plasma source should be specific model for under water cutting. And under water cutting will lose some plasma power and cutting speed.



3. Air extraction

There will be specific cutting table, duct, and filter for air extraction. The filter will collect the dust directly, so there will be no secondary pollution.



1. Zinc Powder Marking Device

Using zinc powder and flame to mark on the plate. The main function of zinc powder marking device is:

- A | Showing the cutting path, test programming correctness
- B | Reservation of welding position line
- C | Point fix marking
- D | Processing road after mark



2. Punching Device

Using compressed air and TAYOR punching head, this punching device can continuously punch all kind of shapes on plate. Also this device can mark the specific points for the further drilling process.



3. Controller Air Conditioner

Controller air conditioner is used for cooling cnc controller, so that the machine can keep on working for long time without crash. This device is mainly used for the customers in hot countries, like South East Asia, Middle East, Africa, etc.



4. Fan-shaped Cutting Torch

Fan-shaped cutting torch was developed by TAYOR, it is easy and economic cutting torch, mainly used to cut small width strip(<40mm).



5. Platen Device

Platen device is mainly used for plasma cutting thin plate. Our company, TAYOR, developed this device and used it to cut thin plate, so that the thin plate will not be deformed.



6. Laser point

In order to make positioning and showing cutting path easier, we developed laser point option for our customer. Customer can see the cutting start point and can check if the plate edge enough for cutting or not.

SHANGHAI TAYOR HEAVY INDUSTRY(GROUP) CO.,LTD.

Shanghai Laike Cutting Machine Co., Ltd

Add: No.3888 South Shenjiang Road,Pudong District,Shanghai

Tel:(+86 21) 5137 7026 | 5137 7027

Fax:(+86 21) 5137 7018

Email: sales@taylorcutting.com | info@taylorcutting.com

www.taylorcutting.com

Authorized Dealer

